

DUMPS ARENA

Aruba Data Center Network Specialist Exam

HP HPE2-W09

Version Demo

Total Demo Questions: 10

Total Premium Questions: 129

Buy Premium PDF

<https://dumpsarena.co>

sales@dumpsarena.co

sales@dumpsarena.co
dumpsarena.co

QUESTION NO: 1

Refer to the exhibit.

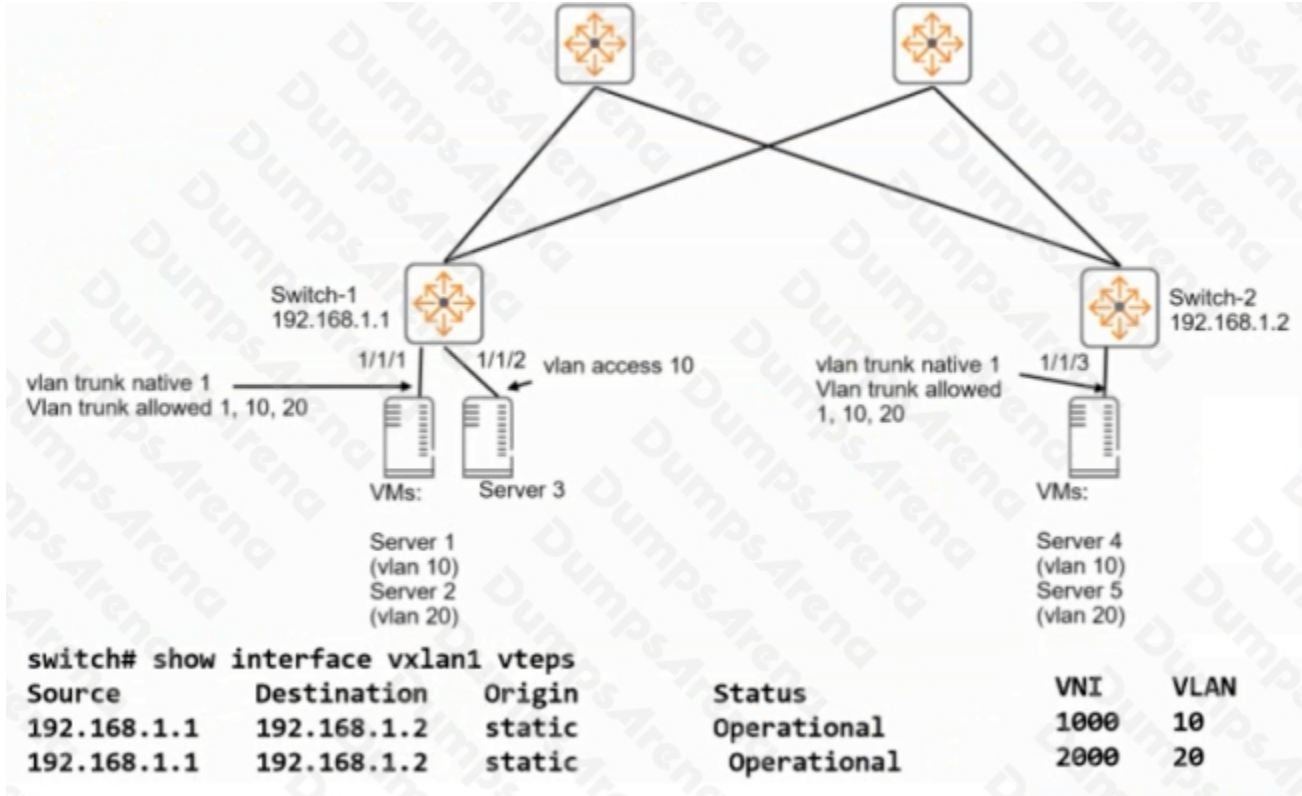

Switch-1 and Switch-2 are ArubaOS-CX switches that implement VXLAN WITHOUT Ethernet VPN (EVPN). Switch-2 uses the same VNI-to-VLAN mappings as Switch-1. Is this how the specified servers communicate?

Solution: The first time that Server 1 communicates with Server 3, it sends an ARP request to resolve Server 3's MAC address.

- A. Yes
- B. No

ANSWER: B

Explanation:

The solution is incorrect because Switch-1 and Switch-2 implement VXLAN without EVPN, which means they do not have a control plane to exchange MAC addresses. Therefore, the first time that Server 1 communicates with Server 3, it sends an ARP request to resolve Server 3's IP address, not MAC address. The ARP request is encapsulated in a VXLAN header and sent to the VTEP of Switch-2, which decapsulates it and forwards it to Server 3.

QUESTION NO: 2

Is this a way that a data center technology can help meet requirements for multi-tenancy?

Solution: Virtual Extensible LAN (VXLAN) provides millions of IDs to scale for the needs of a multi-tenant environment

- A. Yes
- B. No

ANSWER: A**Explanation:**

Virtual Extensible LAN (VXLAN) provides millions of IDs to scale for the needs of a multi-tenant environment is a way that a data center technology can help meet requirements for multi-tenancy. Multi-tenancy is the ability to provide logical separation and isolation of network resources for different tenants or customers on a shared physical infrastructure. VXLAN is a feature that provides Layer 2 extension over Layer

QUESTION NO: 3

A customer's servers use iSCSI, and they send data and storage traffic on the same pair of 10GbE links. Is this a best practice for supporting the iSCSI requirements?

Solution: Set up dedicated switches to connect to iSCSI arrays. Connect top of rack (ToR) switches, which will support both data and storage traffic, to those dedicated switches.

- A. Yes
- B. No

ANSWER: A**Explanation:**

Setting up dedicated switches to connect to iSCSI arrays and connecting top of rack (ToR) switches, which will support both data and storage traffic, to those dedicated switches is a best practice for supporting the iSCSI requirements. [This provides isolation and security for the iSCSI traffic and reduces the risk of congestion or latency on the storage network1.](#)

QUESTION NO: 4

A data center has a three-tier topology with ArubaOS-CX switches at each layer, is this a use case for implementing Virtual Switching Extension (VSX) at the core?

Solution: The customer wants to deploy a single control plane for the core fabric.

- A. Yes
- B. No

ANSWER: B**Explanation:**

[The Virtual Switching Extension \(VSX\) is a high availability solution that provides industry-leading performance and simplicity for campus and data center networks1. VSX does not implement a single control plane for the core fabric, but rather a dual control plane that allows independent software upgrades and configuration changes on each switch2. VSX also provides active-active forwarding and load balancing across both switches, eliminating the need for Spanning Tree Protocol \(STP\) or other loop prevention mechanisms2.](#) Therefore, this is not a use case for implementing VSX at the core. Reference: https://www.arubanetworks.com/assets/tg/TB_VSX.pdf

QUESTION NO: 5

Is this correct positioning of ArubaOS-CX switches in the data center?

Solution: A data center will use a leaf-spine topology and requires 64 leaf switches. Aruba CX 8325 switches can be a good choice for both the leaf and spine switches.

A. Yes

B. No

ANSWER: A**Explanation:**

[ArubaOS-CX switches are designed for enterprise campus, aggregation, and data center networking use cases1. ArubaOS-CX switches support a leaf-spine topology, which is a two-layer network architecture that provides high performance, scalability, and reliability for data center networks2. Aruba CX 8325 switches are compact 1U switches that offer high density and high speed connectivity for both leaf and spine switches3. Aruba CX 8325 switches can support up to 32 ports of 100GbE or 48 ports of 25GbE and 8 ports of 100GbE3.](#) For a data center that requires 64 leaf switches, Aruba CX 8325 switches can be a good choice for both the leaf and spine switches, as they can provide enough bandwidth and port density for the network traffic3. Therefore, this is a correct positioning of ArubaOS-CX switches in the data center, and the correct answer is yes. [For more information on ArubaOS-CX switches and data center solutions, refer to the Aruba Data Center Network Specialist \(ADCNS\) certification datasheet and the Aruba CX Switch Series datasheets3.](#)

QUESTION NO: 6

Refer to the exhibits.

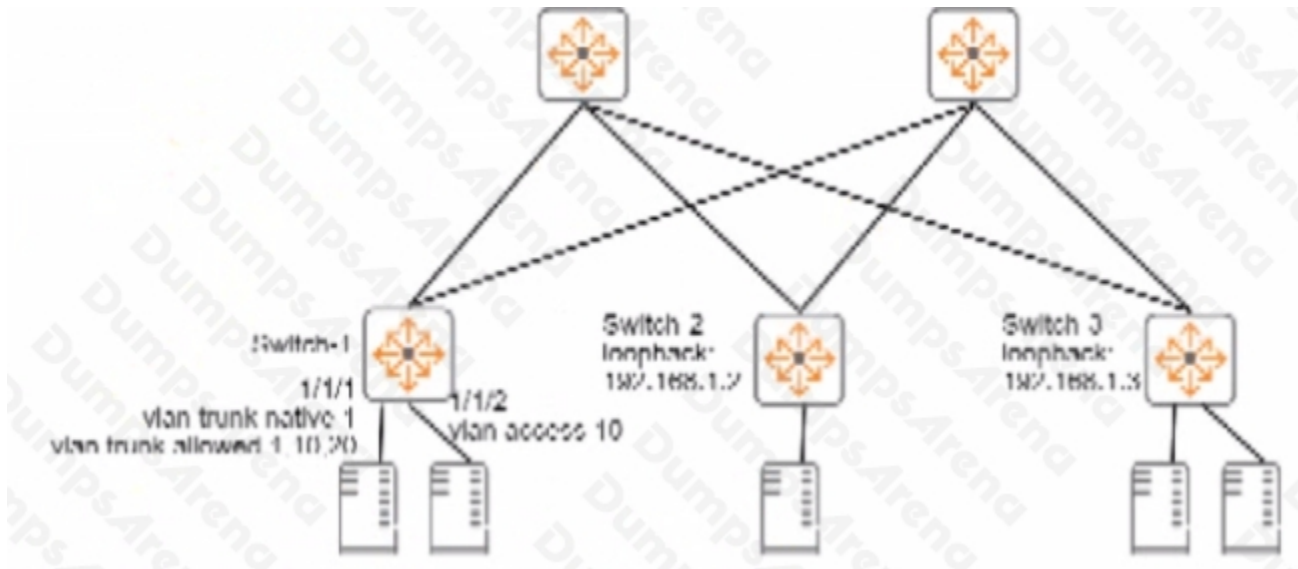

```
Switch-1# show interface vxlan1 vteps
Source          Destination      Origin           Status          VNI    VLAN
192.168.1.1     192.168.1.2    evpn            Operational     5010   10
192.168.1.1     192.168.1.3    evpn            Operational     5010   10
192.168.1.1     192.168.1.3    evpn            Operational     5020   20

Switch-1# show mac-address-table
MAC age-time    : 300 seconds
Number of MAC addresses : 7
MAC Address     VLAN    Type      Port
-----
00:50:56:10:04:25  10     dynamic   1/1/1
00:50:56:11:12:32  10     dynamic   1/1/2
00:50:56:15:16:28  10     evpn      vxlan1(192.168.1.2)
[output omitted]
```

Is this how the switch handles the traffic?

Solution: A broadcast arrives with a VLAN 10 tag on 1/1/1 on Switch-1. Switch 1 drops the frame.

- A. Yes
- B. No

ANSWER: B

Explanation:

Based on the exhibits, Switch-1 has a trunk port on 1/1/1 that allows VLANs 10 and 20. Switch-2 has an access port on 1/1/2 that belongs to VLAN 10. Switch-3 has an access port on 1/1/3 that belongs to VLAN 20. If a broadcast arrives with a VLAN 10 tag on 1/1/1 on Switch-1, Switch-1 does not drop the frame. Instead, Switch-1 forwards the frame to all ports that belong to VLAN 10, which includes the trunk port 1/1/2 and the access port 1/1/4. Switch-2 receives the frame on its access port

1/1/2 and forwards it to all ports in VLAN 10, which includes the access port 1/1/5. Switch-3 does not receive the frame because it is not in VLAN 10. Therefore, this is not how the switch handles the traffic, and the correct answer is no.

QUESTION NO: 7

Is this a best practice when positioning ArubaOS-CX switches in data center networks?

Solution: Deploy Aruba CX 6300 switches as data center spine switches.

- A. Yes
- B. No

ANSWER: B**Explanation:**

Deploy Aruba CX 6300 switches as data center spine switches is not a best practice when positioning ArubaOS-CX switches in data center networks. The Aruba CX 6300 switches are designed for data center leaf roles, and they provide high density, low latency, and advanced features such as VSX and EVPN. The Aruba CX 83xx switches are more suitable for data center spine roles, and they provide high performance, scalability, and resiliency¹.

QUESTION NO: 8

Is this a way that Virtual Switching Extension (VSX) differs from Virtual Switching Framework (VSF)?

Solution: VSX permits admins to select which features to synchronize between members while VSF requires manual configuration of identical features on each member of the VSF fabric.

- A. Yes
- B. No

ANSWER: A**Explanation:**

VSX permits admins to select which features to synchronize between members while VSF requires manual configuration of identical features on each member of the VSF fabric is a way that Virtual Switching Extension (VSX) differs from Virtual Switching Framework (VSF). VSX is a feature that provides active-active forwarding and redundancy for ArubaOS-CX switches. VSF is a feature that provides active-standby forwarding and redundancy for legacy campus switches. [VSX allows admins to select which features to synchronize between members using an opt-in model, while VSF requires manual configuration of identical features on each member using a commander-member model¹.](#)

QUESTION NO: 9

Is this a requirement for implementing Priority Flow Control (PFC) on an ArubaOS-CX switch interface?

Solution: configuring trust of Cos on the interface

A. Yes

B. No

ANSWER: A

Explanation:

Configuring trust of CoS on the interface is a requirement for implementing Priority Flow Control (PFC) on an ArubaOS-CX switch interface. PFC is a feature that allows a switch to pause traffic on a per-class basis using IEEE 802.1Qbb frames. [To use PFC, the switch must trust the CoS values in the incoming frames and map them to priority groups and queues1.](#)

QUESTION NO: 10

Refer to the exhibit.

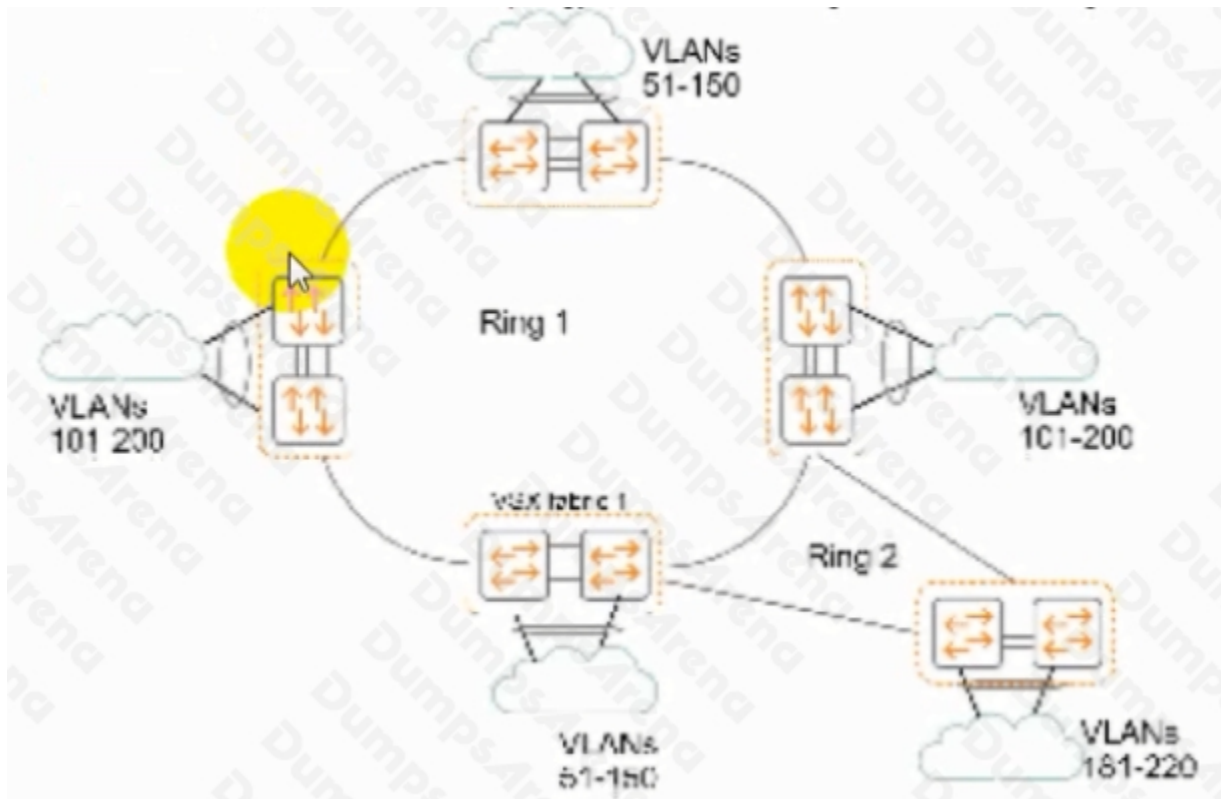

which shows the topology tot an Ethernet Ring Protection Switching (ERPS) solution.

Is this a valid design for the control and protected VLANs on the VSX fabric 1 switches?

Solution: Ring 1, instance 1:

control VLAN: 1000 protected VLANs: 51-135 Ring I, Instance2:

control VLAN: 1001 protected VLANs: 136-220 Ring 2, Instance 1: control VLAN: 1000 protected VLANs: 181 -200 Ring 2, Instance 2: control VLAN: 1003 protected VLANs: 201 -220

A. Yes

B. No

ANSWER: B

Explanation:

Ring 1, instance 1: control VLAN: 1000 protected VLANs: 51-135 Ring 1, Instance 2: control VLAN: 1001 protected VLANs: 136-220 Ring 2, Instance 1: control VLAN: 1000 protected VLANs: 181 -200 Ring 2, Instance 2: control VLAN: 1003 protected VLANs: 201 -220 is not a valid design for the control and protected VLANs on the VSX fabric 1 switches for an Ethernet Ring Protection Switching (ERPS) solution. The control VLANs must be unique for each ring instance and must not overlap with any protected VLANs. In this design, the control VLAN 1000 is used for both ring 1 instance 1 and ring 2 instance 1, which can cause conflicts and errors. [Also, the protected VLANs 181-220 are used for both ring instances on ring 2, which can cause loops and traffic duplication.](#)