

DUMPS ARENA

Lean Six Sigma Master Black Belt

Six Sigma LSSMBB

Version Demo

Total Demo Questions: 15

Total Premium Questions: 400

Buy Premium PDF

<https://dumpsarena.co>

sales@dumpsarena.co

sales@dumpsarena.co
dumpsarena.co

QUESTION NO: 1

In a Fishbone Diagram the 6M's stand for Methods, Measurements, Machine, Man, Mother Nature and _____ .

- A. Management
- B. Merger
- C. Materials
- D. Medical

ANSWER: C**QUESTION NO: 2**

A _____ problem in the Measurement System suggests that there is a lack of consistency in the measurement over time.

- A. Linearity
- B. Bias
- C. Stability
- D. Magnitude

ANSWER: C**QUESTION NO: 3**

Control Charts were developed by Dr. Shewhart to track data over time. To detect Special Cause variation the Control Charts use which of these?

- A. Data shift analysis
- B. Outlier analysis methods
- C. Center Line and Control Limits
- D. None of the above

ANSWER: C

QUESTION NO: 4

Given the image below, what is the main effect of A?

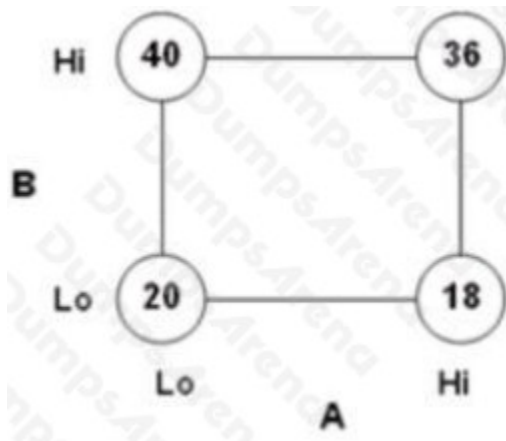

- A. -3
- B. 3
- C. -6
- D. 6

ANSWER: A

QUESTION NO: 5

Choose those characteristics of a Simple Linear Regression (SLR) Analysis that are applicable. (Note: There are 3 correct answers).

- A. The Correlation Coefficient is always greater than the Regression Coefficient in a SLR
- B. General Regression Analysis deals only with Continuous Data
- C. Non-linear Regressions can explain curvature when with more statistical confidence than Linear Regressions
- D. SLR can help quantify the significance of variation in X that influences the variation in Y via a mathematical equation
- E. A Correlation does not explain causation but a Regression Analysis with a statistically valid mathematical equation does explain causation

ANSWER: A D E

QUESTION NO: 6

From this list select the items that define what an X-Y Diagram is. (Note: There are 4 correct answers).

- A. Created for every project
- B. Based on team's collective opinions
- C. Updated whenever a parameter is changed
- D. Used to show each step in a process
- E. A living document throughout project lifecycle

ANSWER: A B C E

QUESTION NO: 7

What aspects of Measurement Systems Analysis (MSA) studies are applicable when the process used to measure does not damage the part?

- A. Destructive variable gage R&R and Crossed Study
- B. Destructive variable gage R&R and Nested Study
- C. Nondestructive variable gage R&R and Crossed Study
- D. Nondestructive variable gage R&R and Nested Study

ANSWER: D

QUESTION NO: 8

Which statement(s) are correct about the Factorial Plot shown here? (Note: There are 3 correct answers).

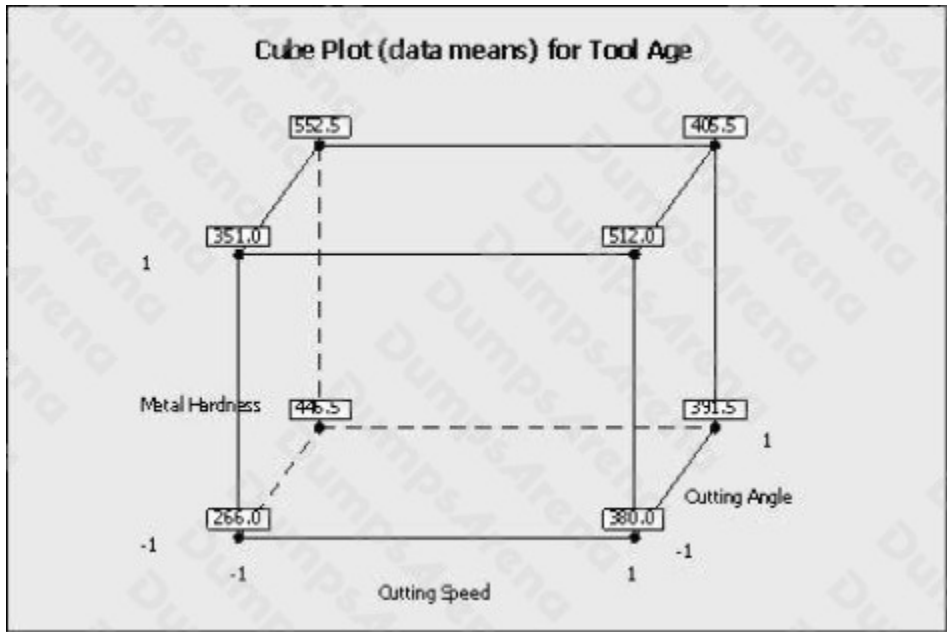

- A. When the cutting speed increased from low to high level, the tool age increases
- B. The coefficient of the metal hardness is positively related to the output of tool age
- C. The coded coefficient is lower for cutting speed than the cutting angle related to the output of tool age
- D. These plots prove a statistically significance factor with 95% confidence
- E. These plots are an example of interaction plots

ANSWER: A B C

QUESTION NO: 9

Which statement(s) are incorrect for the Regression Analysis shown here? (Note: There are 2 correct answers).

Regression Analysis: Turbine Output versus Air-Fuel Ratio, % steam, ...

The Regression Equation is

$$\text{TurbineOutput} = 16.5 + 3.21 \text{ Air-Fuel Ratio} + 0.386 \% \text{ methane} + 0.0166 \text{ SteamExitTemp}$$

Predictor	Coef	SE Coef	T	P
Constant	16.488	2.918	5.65	0.000
Air-Fuel Ratio	3.2148	0.2377	13.52	0.000
% methane	0.38637	0.07278	5.31	0.000
SteamExitTemp	0.016576	0.004273	3.88	0.004

S = 0.508616 R-Sq = 98.6% R-Sq(adj) = 98.2%

Analysis of Variance

Source	DF	SS	MS	F	P
Regression	3	170.003	56.668	219.06	0.000
Residual Error	9	2.328	0.259		
Total	12	172.331			

Source	DF	Seq SS
Air-Fuel Ratio	1	159.048
% methane	1	7.062
SteamExitTemp	1	3.892

- A. The air-fuel ratio explains most of the TurbineOutput variation
- B. The Regression explains over 98% of the process variation
- C. This Multiple Linear Regression has three statistically significant independent variables
- D. If the air-fuel ratio increases by 1, the TurbineOutput more than triples
- E. The SteamExitTemp explains the most variation of the TurbineOutput

ANSWER: D E

QUESTION NO: 10

A(n) _____ is best used to compare a Machine 1 average quality characteristic to the same quality characteristic of Machine 2.

- A. F test
- B. 1-Sample t-test
- C. 2-Sample t-test
- D. ANOVA test

ANSWER: C

QUESTION NO: 11

If an experiment has 5 factors and no replicates for a 2-level Experimental Design with 16 experimental runs which statement(s) are correct? (Note: There are 3 correct answers).

- A. The Main Effects for the 5 factors are not aliased or confounded but the 2-way interactions are confounded with the 3-way interactions
- B. The Main Effects are confounded with only 4-way interactions
- C. The Experimental Design is half-fractional
- D. The experiment has 8 experimental runs with the first factor at the high level
- E. The experiment has only 4 experimental runs with the 5th factor at the high level

ANSWER: B C D

QUESTION NO: 12

The English words used for the 5S's are _____, _____, Shining, Standardizing and Sustaining. (Note: There are 2 correct answers).

- A. Shaping
- B. Sorting
- C. Shifting
- D. Straightening

ANSWER: B D

QUESTION NO: 13

The BEST source of data for assigning an Occurrence Rating in an FMEA is:

- A. Estimates from Industry Experts
- B. Simulated failure rates from reliability models
- C. Best guesses by those preparing FMEA
- D. Historical failure data

ANSWER: D

QUESTION NO: 14

For the data shown here which statement(s) are true? (Note: There are 2 correct answers).

Grade A	Grade B	Grade C
0.917	1.1	0.63
0.68	0.173	4.17
1.74	0.24	0.6
0.3	0.67	0.84
0.33	6.94	0.22
4.13		

- A. With 95% confidence, we cannot conclude if the samples are from three Normal Distributions.
- B. With greater than 95% confidence, we conclude the samples are from Non-normal Distributions.
- C. If we wanted to compare the Central Tendencies of these three samples we would use the one way ANOVA test.
- D. If we wanted to compare the Central Tendencies of these three samples we could use Mood's Median test.

ANSWER: B D

QUESTION NO: 15

A Factorial Experiment based on a Level 2 Design with 4 factors would require 16 runs to fully assess the interactions.

- A. True
- B. False

ANSWER: A